

NORTEL NORSTAR

Norstar ICS
System-wide Call Access (SWCA)
User Card



System-wide Call Appearance (SWCA)

The System-wide Call Appearance (SWCA) feature allows you to park calls on your Norstar system and, at the same time, provide call appearance on telephone buttons with indicators for all telephones that have the same SWCA code programmed onto buttons with indicators. Using this feature frees the line on which the call came in and allows another user to answer the call.

Adding SWCA keys to your telephone

SWCA keys can be assigned by your system administrator to your group of telephones. Or, each user can assign these keys on their own telephones:

1. Enter
2. Select a memory button with an indicator
3. Enter a SWCA code, (to .

Assigning SWCA keys

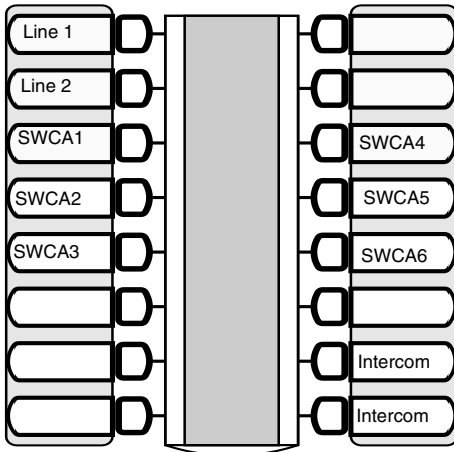

If possible, assign the same set of buttons to the same SWCA user codes for all telephones in the call group.

You can name the keys anything, but it helps to have some reference to the SWCA code that is saved on the key.

If you need to find out which code has been assigned to a button, use Button Inquiry (.

Indicate the label for your SWCA keys

Telephone key #	SWCA code
	<input type="text" value="☎"/> <input type="text" value="*"/> <input type="text" value="5"/> <input type="text" value="2"/> <input type="text" value="0"/>
	<input type="text" value="☎"/> <input type="text" value="*"/> <input type="text" value="5"/> <input type="text" value="2"/> <input type="text" value="1"/>
	<input type="text" value="☎"/> <input type="text" value="*"/> <input type="text" value="5"/> <input type="text" value="2"/> <input type="text" value="2"/>
	<input type="text" value="☎"/> <input type="text" value="*"/> <input type="text" value="5"/> <input type="text" value="2"/> <input type="text" value="3"/>
	<input type="text" value="☎"/> <input type="text" value="*"/> <input type="text" value="5"/> <input type="text" value="2"/> <input type="text" value="4"/>
	<input type="text" value="☎"/> <input type="text" value="*"/> <input type="text" value="5"/> <input type="text" value="2"/> <input type="text" value="5"/>
	<input type="text" value="☎"/> <input type="text" value="*"/> <input type="text" value="5"/> <input type="text" value="2"/> <input type="text" value="6"/>
	<input type="text" value="☎"/> <input type="text" value="*"/> <input type="text" value="5"/> <input type="text" value="2"/> <input type="text" value="7"/>
	<input type="text" value="☎"/> <input type="text" value="*"/> <input type="text" value="5"/> <input type="text" value="2"/> <input type="text" value="8"/>
	<input type="text" value="☎"/> <input type="text" value="*"/> <input type="text" value="5"/> <input type="text" value="2"/> <input type="text" value="9"/>
	<input type="text" value="☎"/> <input type="text" value="*"/> <input type="text" value="5"/> <input type="text" value="3"/> <input type="text" value="0"/>
	<input type="text" value="☎"/> <input type="text" value="*"/> <input type="text" value="5"/> <input type="text" value="3"/> <input type="text" value="1"/>
	<input type="text" value="☎"/> <input type="text" value="*"/> <input type="text" value="5"/> <input type="text" value="3"/> <input type="text" value="2"/>
	<input type="text" value="☎"/> <input type="text" value="*"/> <input type="text" value="5"/> <input type="text" value="3"/> <input type="text" value="3"/>
	<input type="text" value="☎"/> <input type="text" value="*"/> <input type="text" value="5"/> <input type="text" value="3"/> <input type="text" value="4"/>
	<input type="text" value="☎"/> <input type="text" value="*"/> <input type="text" value="5"/> <input type="text" value="3"/> <input type="text" value="5"/>

No assigned SWCA keys

You can use SWCA codes without having SWCA codes assigned to buttons with indicators, but in that case, you need to use the other features of the system, such as Voice Call or Page, to indicate to other users on which code the call has been parked. You must have an intercom key free on which to retrieve the call.

Managing calls using SWCA buttons

Receiving a call

Incoming calls may either automatically assign themselves to a free SWCA key when the call is answered

OR

you may need to press a free SWCA key to assign a call and park it on that key.

Your system administrator will indicate how your system works.

You can also enter the SWCA code that corresponds to the key while you are on the call.

Incoming call assigns to a SWCA key

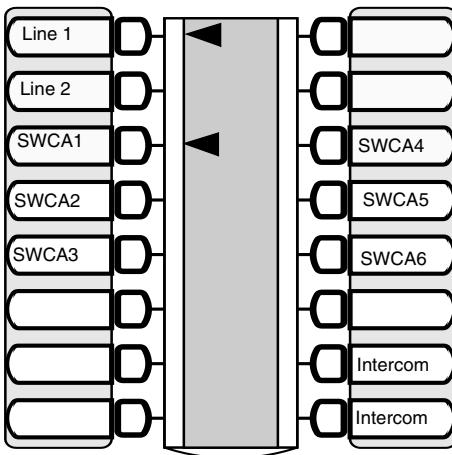

In this example, the call comes in on line 1 and automatically transfers to SWCA1 (the first free SWCA key).

The solid indicator beside SWCA1 and beside the line key indicates that the call is active on this telephone and it has not yet been parked.

On all other telephones in the group, the indicator would be solid only beside SWCA1. The line keys for the other telephones would be free to receive additional calls.

If you press SWCA1 again to park the call, the line indicator disappears and the indicator beside SWCA1 starts blinking on all telephones in the group, indicating that the call is available to be picked up.

No available SWCA keys

If all your SWCA keys have calls assigned to them, and you receive another call, you can:

- put the call on Hold on your line key until a SWCA key becomes free, at which point you can take the call off Hold and press the free SWCA key to park the call.
- dial in a SWCA code that is not assigned to a button on your telephone. If you assign a call to a code that does not have an appearance on your telephone, you need to use the Page or Message feature to tell the group that there is a call waiting, and on which code it was parked.

Retrieving a call from a SWCA keys



If the indicator beside a SWCA key is blinking, you can retrieve the call by picking up the handset and pressing the SWCA key associated with the indicator.

You can also pick up your handset and enter the appropriate feature code to pick up the call.

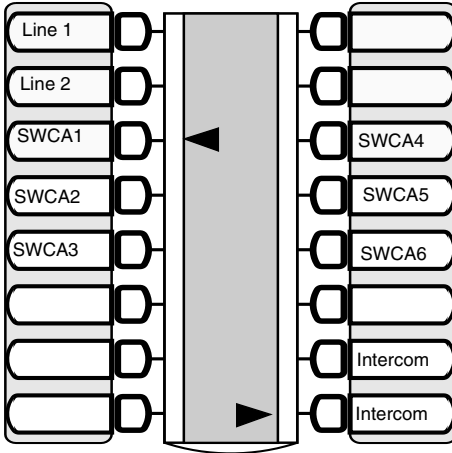

In this example, the call parked on SWCA1 was retrieved by this user by pressing the SWCA1 key.

The flashing indicator beside SWCA1 becomes solid.

As well, a solid indicator appears beside one of the user's intercom buttons.

On all other telephones in the group, the indicator displays solid beside SWCA1, indicating that the call has been retrieved and is active.

Using Hold with SWCA keys



Your system administrator will tell you how Hold acts in terms of the assigned SWCA keys.

If you put a call on Hold, it will either:

- automatically assign to a free SWCA key (press the key again to park the call)
- OR
- remain on hold on the line at your telephone. To park this call on a SWCA key, unhold the call (press ) , then press a free SWCA key.

Outbound calls

You can also park calls on a SWCA that you dial. If your system is set up to automatically assign calls to a SWCA key, as soon as you dial a call it will assign to a key. Otherwise, during your call, you can press a free SWCA key to park the call and make it available to other users in the group.